



RTWA 207 - 217

**Screw compressor liquid chiller,
water cooled.**

Two independent circuits.

- **Packaged unit.**
- **Nominal cooling capacity : 140 to 400 kW (R134a, 50 Hz).**
- **TRANE Helirotor screw compressor.**
- **Microprocessor based stepless capacity control.**
- **«Adaptive Control™» providing superior operation reliability.**
- **Easy integration in a Building Management System.**
- **Electronic expansion valves.**
- **Factory tested prior to shipment.**
- **Designed and manufactured in accordance with the TRANE Quality Management System, approved to ISO 9001.**



Quality Management System Approval

B20 CA 013 E

**RTWA. Helirotor screw compressor liquid chiller, water cooled.
Nominal cooling capacities: 140 to 400 kW (R134a, 50Hz).**

TRANE : Number 1 in rotary compressors applications.



By introducing the RTWA, TRANE is now able to offer a complete range of liquid chillers fitted with rotary compressors covering the cooling capacity range from 50 up to 4000 kW. For the largest cooling capacities, TRANE offers the centrifugal compressor liquid chillers. These machines have an excellent reputation for reliability. A survey published in the USA in 1988 revealed that more than 90% of the cen-

trifugal chillers installed during the 50 last years were still in operation.

For lower cooling capacities, TRANE has introduced more recently, the 3-D™ Scroll compressors and the Helirotor Screw compressors. Despite these technologies still being considered a novelty in some quarters, within TRANE this relates to today's technology: for example the 3-D™ Scroll compressors introduced in



1989 have completely replaced the reciprocating compressors for cooling capacities up to 160 kW. For the upper range, the water-cooled Screw compressor liquid chillers, series RTHA, introduced in 1988, is a very successful product :

with more than 1500 machines installed every year worldwide, TRANE can be considered as the Number 1 in this area. TRANE has also introduced a range of air cooled Screw compressor liquid chillers.

Whatever the type of technology, the rotary compressors offer some very specific common benefits : superior energy efficiency and reliability combined with reduced sound and vibration level being the most obvious ones.



RTWA: A combination of the latest technological innovations in the field of liquid chillers.

The RTWA offers in many areas a combination of the most advanced technologies available today:

- Screw compressor, with stepless capacity control and 5/7 lobes rotors profiles designed and patented by TRANE.
- Advanced microprocessor based «Adaptive Control» including PID leaving chilled water temperature control and a serial communica-

tion link for easy integration into a Building Management System.

- Electronic expansion valve. Gives steadier operation, optimized evaporator efficiency and improved energy efficiency with reduced condensing pressure.
- High efficiency heat exchange surfaces : energy efficiency combined with reduced surface area.

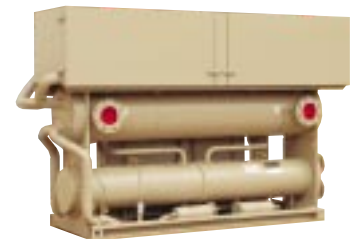

RTWA : Designed to offer more attractive benefits in all areas.

For the specifier :

- High energy efficiency, less floor space required : the unit can be more easily integrated into an existing plant room, which allows for an increase of the available cooling capacity.
- Higher application flexibility : ice storage, multiple operating conditions
- Reduced sound and vibrations levels allowing installation in sensitive areas.

For the mechanical contractor :

- Compact design, reduced shipping weight : easier handling during site transportation.
- Condenser hydraulic connections possible from both sides allowing easier integration into the plant room.
- Fully factory tested reducing the commissioning cost and labour.

For the operating contractor :

- State of the art motor protection : the unit control module permanently

senses the current of each phase of the motor power supply as well as the temperature of the motor windings.

- «Adaptive Control™», anticipates any operating problems : the control module consequently takes corrective actions to enable the chiller to stay within operating limits to guarantee trouble free operation even under critical conditions. The chiller can continue to operate at a reduced load under these critical conditions until normal operation can be restored whereas a standard chiller would just stop as a fault.

- Sophisticated operator interface : the clear language display board allows for a quick and precise identification of the operating status of the machine or of an operating fault.
- Serial link allows for a remote monitoring of the chiller.

For the owner :

- Superior energy efficiency reducing operating costs.
- Increase chiller life and drastically reduced maintenance costs : the compressors have been designed to operate for the whole life of the chiller without any major maintenance operations.
- Steady and safe operation : thanks to the stepless capacity control, the electronic expansion valve and the sophisticated control algorithms, the chiller can exactly match the required cooling capacity and maintain the chiller water outlet temperature within a range of $\pm 0.3^{\circ}\text{C}$ of the setpoint.
- Serial communication link facility to start and stop the chiller, modify the setpoints or to limit the current drawn from a remote location.



TRANE Helirotor Screw compressors: Superior energy efficiency and reliability.

- **Less critical components** : only two rotating parts, reduced number of components and particularly of critical parts (the total number of critical components is on average 30 times lower compared to a standard reciprocating chiller)
- **Rugged design** : all potentially fragile components (suction and discharge valves, springs) have been eliminated. The compressors are fitted with class 5 bearings designed not to be replaced during compressor life time.
- **High precision machining** : the very precise rotor tip tolerance (10 micrometers) is achieved due to the most advanced machine tools available today. TRANE is able to build screw compressors with a reduced amount of leakage between the high and low pressure cavities. As a result, the energy efficiency of the compressor is considerably improved compared to the first generation of screw compressors

which were in some cases derived from air compression technology.

- **Rotary compressor** : reduced sound and vibration level compared to reciprocating equipments. The overall sound level is lower and furthermore the shape of the sound spectrum is different : the sound level is inferior in the low frequencies bands.
- **Proven Design Through Testing and Research** : at TRANE, we MUST fail compressors in the Laboratory to ensure they will not fail in the field. Without failures, there is no way to be certain whether the final design is satisfactory or potentially unreliable. The compressor accelerated life test is a proven method to induce failure. This test is designed to overstress all parts and quickly identify any weak areas. The

extreme test conditions far exceed actual field applications. TRANE engineers fail and redesign compressors until a reliable product is assured. Our leadership in helical rotary compressor techno-

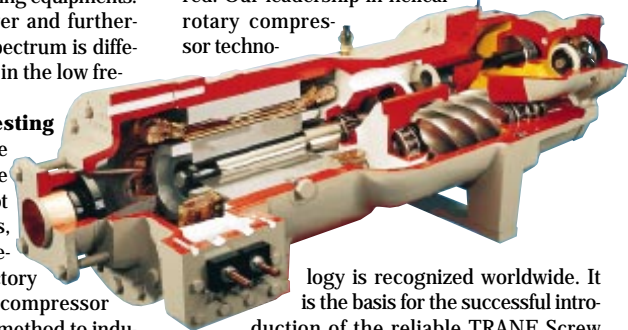

logy is recognized worldwide. It is the basis for the successful introduction of the reliable TRANE Screw compressor, right from the start !

HFC 134a : A new non-flammable, non-toxic, chlorine-free refrigerant with zero ozone depletion potential.

HFC 134a is very well suited to replace CFC 12 but also HCFC 22 in most liquid chiller applications, in particular for centrifugal, screw and scroll compressor comfort cooling and process chillers.

HFC 134a is listed in the European EINECS-inventory of approved chemical compounds for which no further toxicity testing is required by the regulation.

The voluntary toxicity testing programme which includes **HFC 134a** (PAFT 1), a cooperative research effort of the 15 leading chemicals compa-

nies in the world, was undertaken to facilitate and accelerate the phase out of CFC's.

The PAFT programme on **HFC 134a** is now complete.

All PAFT members have set the recommended occupational exposure limit for **HFC 134a** at 1000 ppm, the highest level that is ever assigned to any industrial chemical. This OEL-level confirms the extremely low toxicity of this refrigerant.

Extensive research and development efforts in TRANE's corporate R+D laboratories were neces-

sary to adapt the proven RTWA chiller design to the environmentally acceptable refrigerant **HFC 134a**.

Suitable lubricants and sealing materials had to be identified, screened and extensively tested and their compatibility established.

The result of this R+D programme is an advanced chiller design which combines a proven mechanical concept, unmatched reliability and a safe, environmentally-acceptable refrigerant.

Electronic expansion valve

When coupled with Trane «Adaptive Control™» microprocessor, the electronic expansion valve significantly improves part load performance of the RTWA chiller by minimizing superheat in the evaporator and allowing the chiller to run at reduced condensing pressures.

Chillers which use conventional TXV must run at higher head pressures and consume more power at part load than necessary.

Additionally the electronic expansion valve and its control allow much better control over dynamic load and head changes. Under these conditions a conventional TXV may never achieve control stability and "huntings" and liquid slugging are common.

Precise refrigerant flow metering

The electronic expansion valve is actuated by a stepper motor. The exact valve position is permanently known by the Unit Control Module.

Quick response

To operate the valve from fully closed to fully open position requires less than 30 seconds. This is to compare with thermo-electric devices which have no stable position and require up to several minutes to fully close.

Superior tightness

Because of the superior tightness of the electronic expansion valve when full closed the liquid line solenoid valve is no more required.

It enables to further improve the reliability of the chiller by reducing the total number of moving parts.

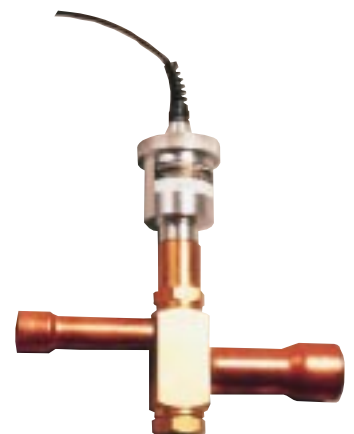

«Adaptive Control™» Trouble-free installation, start-up and operation.

Trouble-free operation

The water cooled series RTWA utilizes the most advanced microprocessor control issued from the latest development in micro-electronics.

Control and protection of chiller were the two functions of previous chiller control design. «Adaptive Control™» keeps the chiller on line and makes the control "intelligent".

The «Adaptive Control™» means the system takes corrective action when any of the control variables approaches a limit condition at which the protection function of previous control schemes would normally shut down the chiller. Corrective action is achieved through combined actions of compressor unloader mechanism, electronic expansion valve modulation. Only when the control system has exhausted the corrective actions it can take and the unit is still violating an operating limit, the unit will be shut down.

The control logic of the P.I.D. type based on the leaving chilled water temperature integrates the control of variables (current drawn by the motor, evaporating and condensing temperature) maintains accurate control, minimizes the drift from the setpoint and provides better building comfort.

Improved chiller and motor protection

The control system integrates all the functions necessary to ensure safe operation of the chiller in all applications and duty conditions :

- System safeties, such as oil, water, refrigerant pressure and temperature faults.
- Motor safeties. By monitoring the motor current on each of the 3 phases, the control system ensures protection against :
 - Overload at start-up and in operation.
 - Phase loss/Power loss.
 - Phase unbalance or reversal.
 - Over/Under voltage.
 - Welded contactors.

If a fault occurs, one of over 90 individual diagnostic and operating codes will displayed directly on the control module.

«Adaptive Control™», features summary

- Ensures safe operation of the chiller.
- Keeps chiller on line.
- Optimizes total chiller power consumption.
- Ensures total chiller reliability.
- Allows easy interface.
- Minimizes service expense.



Optional features

- Communication interface.
- External chilled water setpoint.
- External current limit setpoint.
- Ice making control.
- Chilled water temperature reset.

Operator interface

Easier than ever to use

The microprocessor is equipped with a two-line, forty character Clear Language Display. The display shows over 90 operating and status points. The control panel will display the most current diagnostic message and store the last 10 for more accurate diagnosis by Service personnel. Having the ability to diagnosis a problem via the control display will lower the service expense, as well as the downtime of the chiller.

Readability

Local operator interface with the system is accomplished using the 16 keys on the front of the Clear Language Display panel. The readout screen is a two line, 40 character liquid crystal with a backlight. The backlight allows the operator to read the display in low light conditions. The depression of any key will active the backlight.

Application flexibility

The UCM CLD is available with the output in six languages and either English or metric units.

Communication

The Unit Control Module (UCM) of the RTWA offers several communication levels which considerably simplify the implementation of a telemonitoring of the chiller or its integration in a Building Management System (BMS).

Telemonitoring through a parallel link

Analog input and output ports allow chiller operation optimization or easy chiller monitoring when the machine is not integrated in a BMS.

Remote running and alarm contacts

The unit provides three single pole/double-throw contact closures to indicate whether :

- a failure has occurred,
- the compressor is running,
- the compressor is running at maximum capacity. This information may be used to authorize the start of an additional chiller.

External chilled water setpoint and current limit setpoint

The UCM allows the external setting independent of the front panel setpoint by one of the following three means (option):

- a remote resistor (fixed or adjustable)
- a 2-10 VDC input
- a 4-20 mA input.

In the same way, the motor current can be limited to optimize the total energy efficiency of the installation.

Integration in the Building Management System through the Serial link

The unit can be equipped upon request with a serial link communication card. All the data and functions available at the UCM front panel can be transmitted or accessed through the serial link.

Data which can be read

Following parameters can be read by the BMS through the serial link :

- Entering leaving evaporator water temperature.
- Entering leaving condenser water temperature.
- Motor current.
- Operating status : compressor stopped or running, compressor running at full load or auto-limitation.

More than 100 data can be accessed or transmitted.

Orders which can be sent to the chiller

The BMS can send following orders :

- Compressor start and stop.
- Motor current limit.
- Chilled water setpoint reset.

Superior «Adaptive Control™»

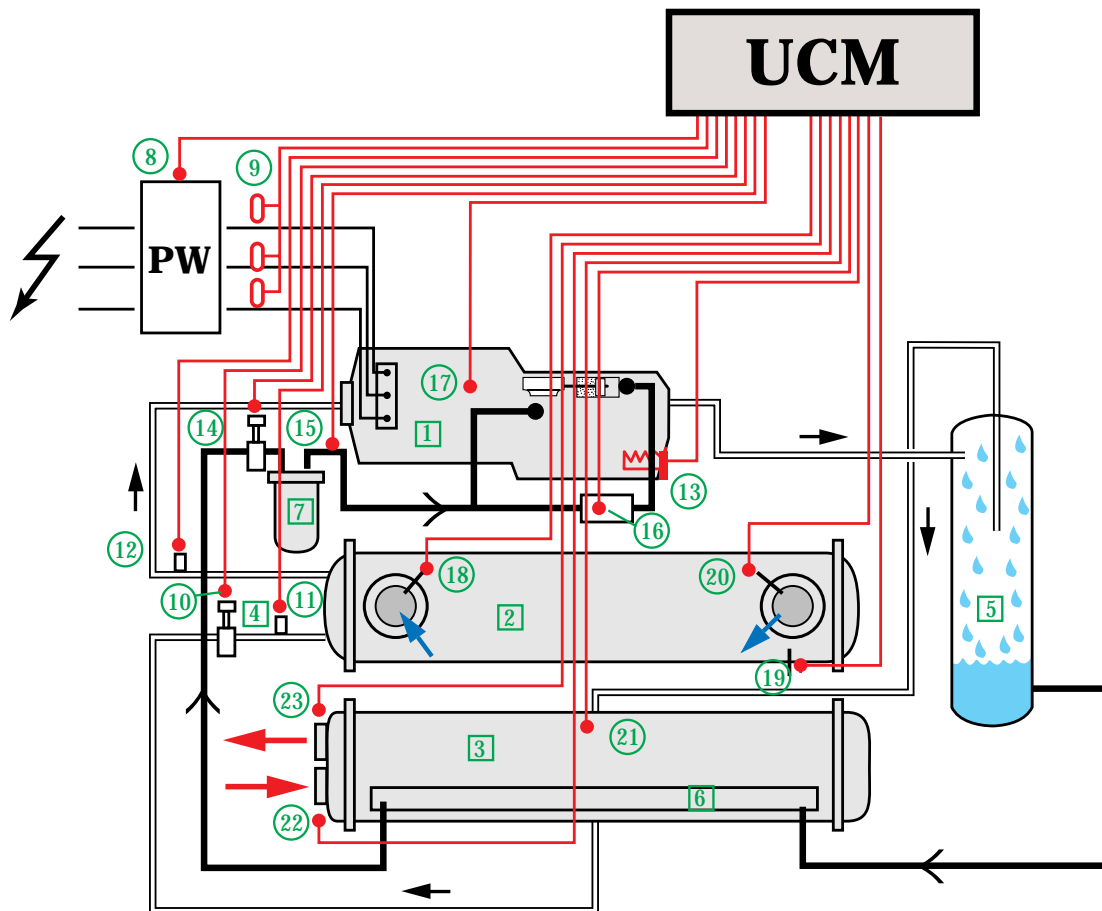

Refrigeration circuit

- 1 Compressor
- 2 Evaporator
- 3 Condenser (with integral subcooler)
- 4 Electronic expansion valve

Lubrication circuit

- 5 Oil separator
- 6 Oil cooler
- 7 Oil filter.

Control circuit

- 8 Part-winding starter
- 9 Phase loss/imbalance, under/over voltage protection
- 10 Electronic expansion valve self diagnostic and prepositionning, refrigerant flow metering
- 11 Evaporator entering refrigerant temperature
- 12 Evaporator leaving refrigerant temperature
- 13 Oil tank heating
- 14 Oil circuit solenoid valve
- 15 Oil pressure
- 16 Compressor capacity control
- 17 Motor windings temperature
- 18 Evaporator entering water temperature
- 19 Evaporator leaving water temperature
- 20 Chilled water circuit flow switch (option, field wired)
- 21 Condenser refrigerant temperature
- 22 Condenser entering water temperature
- 23 Condenser leaving water temperature

Remote control panel

TRANE RTWA chiller is available with twisted pair connection to a remote control panel. Chiller operation can be controlled similarly to the control interface on the chiller itself. All through a twisted pair of wire unit can be turned on or off, change the

chilled water setpoint, and display over 90 diagnostics conditions. Remote control panel can be mounted so access to chiller information is just step away and no need to go into the chilled water plant.



Performance data

Unit Size RTWA	Leaving chilled water temperature (°C)	Leaving condenser water temperature (°C)					
		30		40		50	
		Cooling Cap. (kW)	Power Input (kW)	Cooling Cap. (kW)	Power Input (kW)	Cooling Cap. (kW)	Power Input (kW)
207	5	145	37	125	41	108	46
	7	156	38	135	42	116	47
	9	168	39	145	43	125	48
209	5	177	43	152	48	131	54
	7	191	44	164	49	141	55
	9	205	45	176	50	152	56
211	5	221	50	190	55	164	62
	7	238	51	205	56	177	63
	9	256	52	220	57	190	64
212	5	258	57	222	63	191	72
	7	278	58	239	64	206	73
	9	299	59	257	65	222	74
213	5	297	68	261	76	227	87
	7	319	70	281	77	245	89
	9	341	72	302	80	264	91
215	5	334	77	296	86	260	98
	7	360	79	320	88	282	101
	9	388	81	346	90	306	103
216	5	363	84	321	93	283	106
	7	390	87	347	96	306	109
	9	419	90	373	99	330	112
217	5	397	92	351	100	308	114
	7	427	95	378	104	332	117
	9	458	99	405	107	358	120

(1) With Δ T evaporator : 5°C, Δ T condenser 5°C, fouling factor : 0.044 m² K/kW, standard heat exchangers, electrical power supply 50Hz, refrigerant R134a.

General data

Unit size	RTWA	207	209	211	212	213	215	216	217	
Nominal motor rating	(kW)	49	56	65	76	82	89	89/98	98	
Compressor type	CHHN	35	40	50	60	CHHB 70	85	85/100	100	
Capacity modulation capability		-- Continuous: 17-100 % --					-- Continuous: 10-100 % --			
Starting amps (1)(2)	(A)	262	322	400	474	377	440	548	566	
Maximum amps (1)(3)	(A)	110	126	148	180	216	238	262	286	
Oil heater	(W)	150	150	150	150	150	150	150	150	
Control circuit	(VA)	1600	1600	1600	1600	1600	1600	1600	1600	
Heat exchanger type										
Evaporator		ES70	ES80	ES100	ES120	ES140	ES170	ES170	ES200	
Condenser		CS60	CS80	CS100	CS120	ES140	ES170	ES170	ES200	
Water content										
Evaporator	(l)	145	134	118	106	269	223	223	204	
Condenser	(l)	22	27	32	38	34	42	42	49	
Operating charges										
Refrigerant	(kg)	2 x 30	2 x 32	2 x 34	2 x 36	2 x 55	2 x 60	2 x 60	2 x 65	
Oil	(l)	2 x 8	2 x 8	2 x 8	2 x 8	2 x 14	2 x 14	2 x 14	2 x 14	
Operating weight (4)	(kg)	2270	2295	2322	2397	3010	3215	3360	3415	

(1) 400V/50Hz/3Ph power supply.

(2) With part winding start-one compressor at full load, the other one starting.

(3) To be taken in account for the sizing of power cables.

(4) With compressor sound enclosure, refrigerant and oil operating charge and heat exchanger water content.

Dimensions

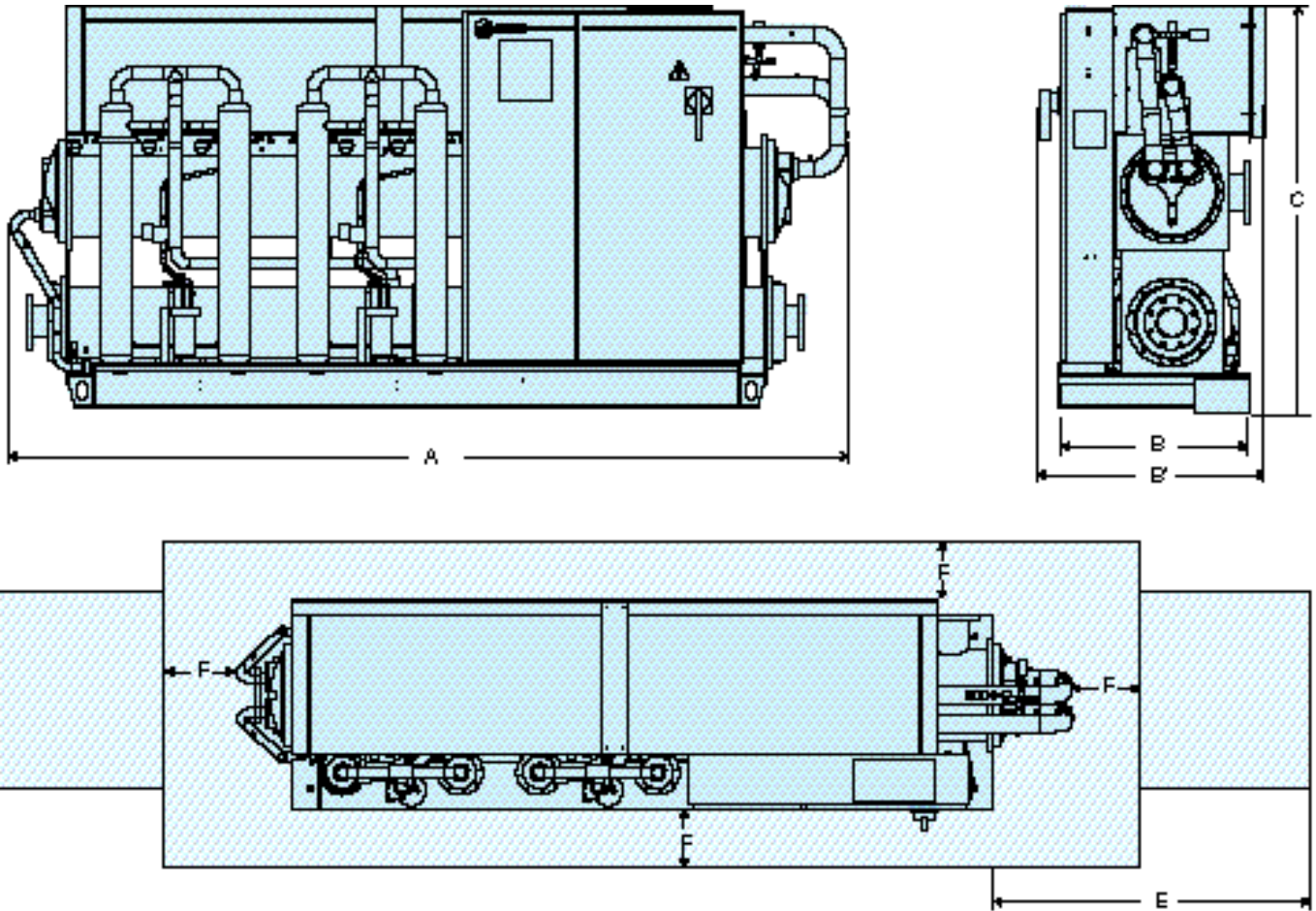

Minimum clearance for usual maintenance

Unit size	RTWA		213	215	216	217
Length	A	(mm)	3868	3868	3868	3868
Width	B	(1) (mm)	885	885	885	885
	B'	(2) (mm)	1040	1040	1040	1040
Height	C	(2) (mm)	1813	1813	1813	1813
Clearance	E	(3) (mm)	3000	3000	3000	3000
	F	(4) (mm)	800	800	800	800

Hydraulic connection

Evaporator

----- Flanges 5" / DN125 / PN16 -----

Condenser 1 pass

----- Flanges 3" / DN 80 / PN16 -----

Electrical connection	(mm)	130 x 300	130 x 300	130 x 300	130 x 300
					130 x 300

(1) With compressor sound enclosure and disconnect switch handle removed.

(2) With compressor sound enclosure and disconnect switch handle mounted.

(3) Clearance for retubing : can be on either end of the chiller

(4) Clearance all around the unit in order to achieved usual maintenance operations.

Water side pressure drop

Evaporator

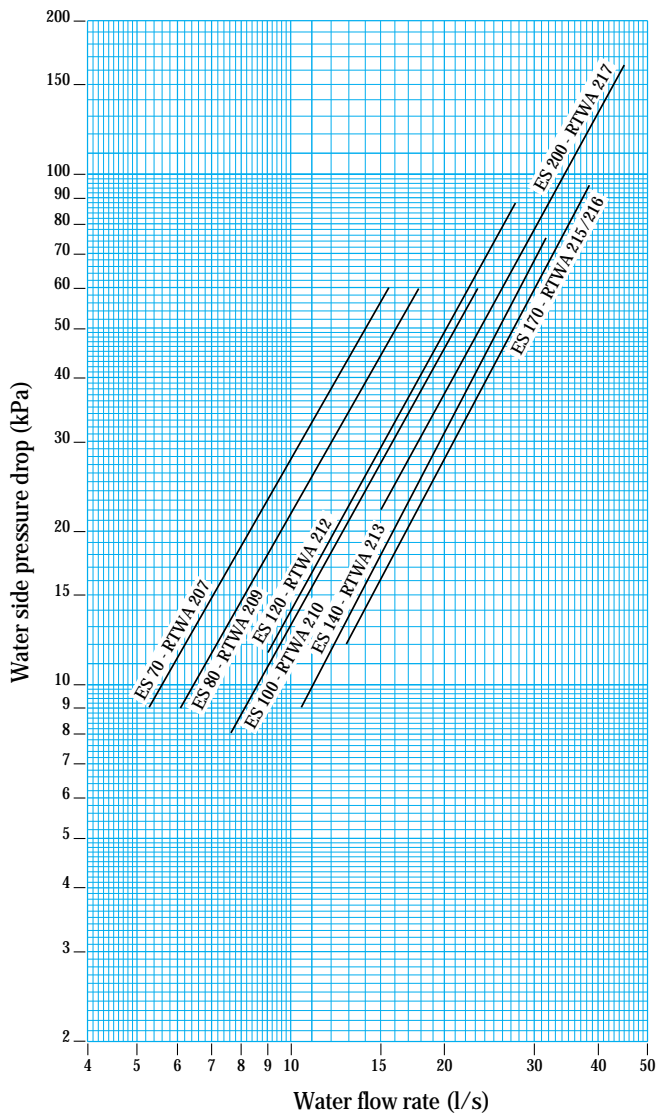

Condenser

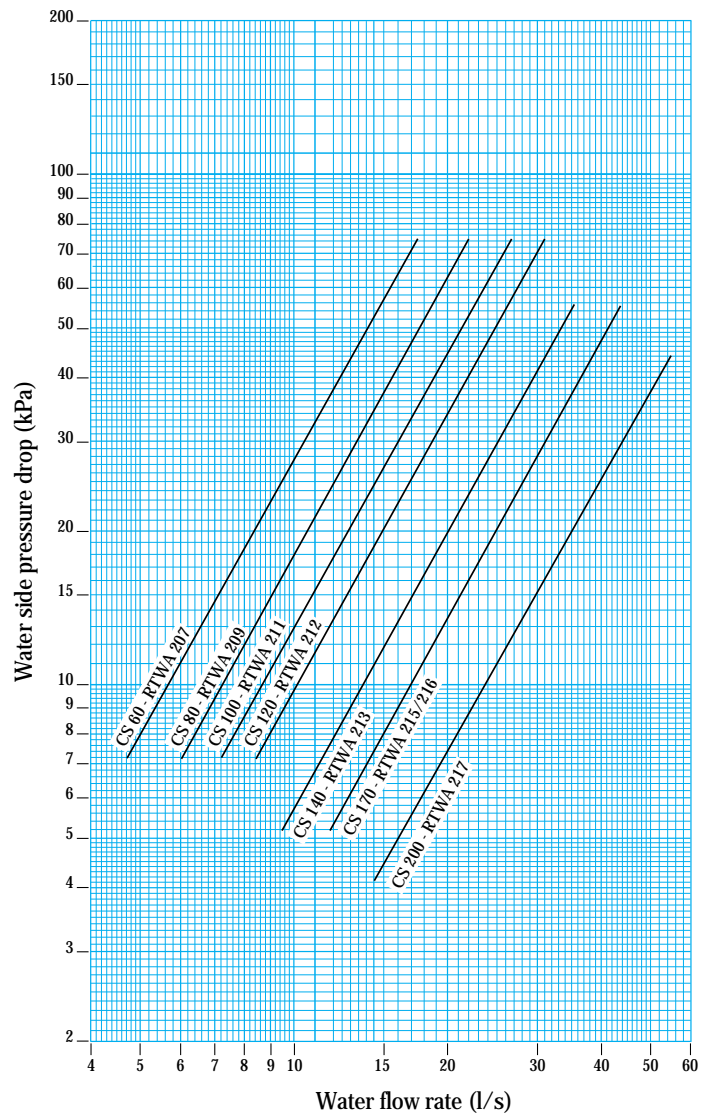

Mechanical specifications

Packaged liquid chiller, series RTWA, fitted with semi-hermetic direct drive screw compressor, shell and tube evaporator and condenser, microprocessor based «Adaptive Control™» module, factory mounted starter panel. Units are factory run tested prior to shipment and delivered ready to operate.

General construction

Welded evaporator, condenser assembly fitted on a structural steel profiles frame.

Compressor supporting plate designed to allow installation of the compressor sound enclosure on site.

Double door electrical panel.

Compressors and lubrication oil system

Two semi-hermetic, accessible direct drive, 2950 rpm dual screw compressor with :

- Capacity control slide valve oil pressure actuated.
- Pressure lubricated, class 5 rolling element bearing groups support the rotor assembly.
- Squirrel cage induction motor, refrigerant suction gas cooled and hermetically sealed.

Oil separator, oil cooler and filtration devices are provided separate from the compressor. Check valves in the compressor discharge and lube oil system and a solenoid valve in the lube system are provided.

Heat exchangers

Shell and tube heat exchangers. Carbon steel shell plates and tube sheets. Tubes sheets are drilled reamed and grooved to accommodate tubes. Individually replacable tubes, mechanically expanded into tube sheets and fastened into intermediate tube supports made of carbon steel (condenser) or plastic (evaporator). Headers of high strength cast steel bolted to the tube sheets. Self energizing type gaskets requiring low bolt torque.

Direct expansion type evaporator. Factory insulated with 19mm Armaflex type foam. internally

finned 5/8 inch diameter tubes. Maximum operating pressure : water side and refrigerant side = 1.4 MPa.

Flooded type condenser with removable water boxes, easily cleanable, integral subcooler and oil cooler. Internally and externally finned 3/4 inch diameter tubes. Maximum operating pressure : water side = 2.5 MPa, refrigerant side = 1.4 MPa.

Two independent refrigerant circuits

Each circuit includes : electronic expansion valve minimizing evaporator superheat, removable core filter drier, liquid line shut off valve.

Control panel

All unit controls are housed in a watertight enclosure. Removable plate on the top of the enclosure to allow customer connection of power wiring and remote interlocks.

Microcomputer control provides all control functions including start-up and shut down, leaving chilled water temperature control, compressor and expansion valve modulation, antirecycle logic and load limiting.

«Adaptive Control™» microprocessor prevents unit shutdown due to abnormal operating conditions associated with low refrigerant temperature, high condensing temperature and motor overload.

Unit protective functions include loss of chilled water flow, evaporator freeze protection, low or high refrigerant pressure, reverse rotation, compressor starting and running over current, phase loss, phase imbalance, phase reversal and loss of oil flow.

The Clear Language Display (CLD) eliminates coded informations. Information available with the «Adaptive Control™» microprocessor includes: entering and leaving water temperatures, evaporator and condenser refrigerant temperatures and pressures, compressor suction temperature, compressor start and running hours, chilled water setpoint, over 90 diagnostic and operating conditions.

Starter panel

Part winding starters. Typically TRANE helirotor screw compressor are up to full speed in less than one second.

Rigging

4 liftings lugs are provided on the unit base frame.

Option and accessories

- Ice making module
- Communication interface/Remote control display board
- Ammeter-voltmeter
- Compressor sound enclosure
- Disconnect switch
- Pressure gauges.

Factory run tests

Pressure test on each individual component (before assembly) and on the refrigeration circuit (when fully assembled).

All RTWA units are fully run tested prior to shipment. Unit operation and all controls are thoroughly checked.

Shipment

All units are ship with the refrigerant and operating charge, fully assembled and wired, ready for immediate starting. Commissioning work is limited to electrical and hydraulic connections.

Quality assurance

The Quality Management System applied by TRANE has been subject to independent third party assessment and approval to ISO 9001. The products described in this catalogue are designed, manufactured and tested in accordance with the approved system requirements as described in the Trane Quality Manual.

Trane reserves the right to alter any information without prior notice.

B20 CA 013 E - 0497 •

Supersedes B20 CA 013 E - 1096

